

DATA SHEET

TDA1516CQ 24 W BTL car radio power amplifier

Product specification
File under Integrated Circuits, IC01

July 1994

24 W BTL car radio power amplifier

TDA1516CQ

FEATURES

- Requires very few external components for Bridge-Tied-Load (BTL)
- High output power (without bootstrap)
- Low offset voltage at output (important for BTL)
- Fixed gain
- Good ripple rejection
- Mute/stand-by switch
- Load dump protection
- AC and DC short-circuit-safe to ground and V_P
- Thermally protected
- Reverse polarity safe
- Capability to handle high energy on outputs ($V_P = 0$)
- Protected against electrostatic discharge
- No switch-on/switch-off plop
- Flexible leads
- Low thermal resistance
- Identical inputs (inverting and non-inverting).

GENERAL DESCRIPTION

The TDA1516CQ is a monolithic integrated class-B output amplifier in a 13-lead single-in-line (SIL) plastic power package. The device is primarily developed for car radio applications.

QUICK REFERENCE DATA

SYMBOL	PARAMETER	CONDITIONS	MIN.	TYP.	MAX.	UNIT
V_P	positive supply voltage range	operating	6.0	14.4	18	V
		non-operating	–	–	30	V
		load dump	–	–	45	V
I_{ORM}	repetitive peak output current		–	–	4	A
I_P	total quiescent current		–	40	80	mA
I_{sb}	stand-by current		–	0.1	100	μ A
I_{sw}	switch-on current		–	–	60	μ A
$ Z_i $	input impedance BTL		25	–	–	k Ω
T_{XTAL}	crystal temperature		–	–	+150	$^{\circ}$ C
P_O	output power	THD = 10%; 4 Ω	–	22	–	W
SVRR	supply voltage ripple rejection	$R_S = 0$; $f = 100$ Hz	45	–	–	dB
		$f = 1$ to 10 kHz	48	–	–	dB
V_{no}	noise output voltage		–	70	–	μ V
$ \Delta V_{os} $	DC output offset voltage		–	–	100	mV

ORDERING INFORMATION

EXTENDED TYPE NUMBER	PACKAGE			
	PINS	PIN POSITION	MATERIAL	CODE
TDA1516CQ	13	DIL	plastic	SOT141 ⁽¹⁾

Note

1. SOT141-6; 1996 August 21.

24 W BTL car radio power amplifier

TDA1516CQ

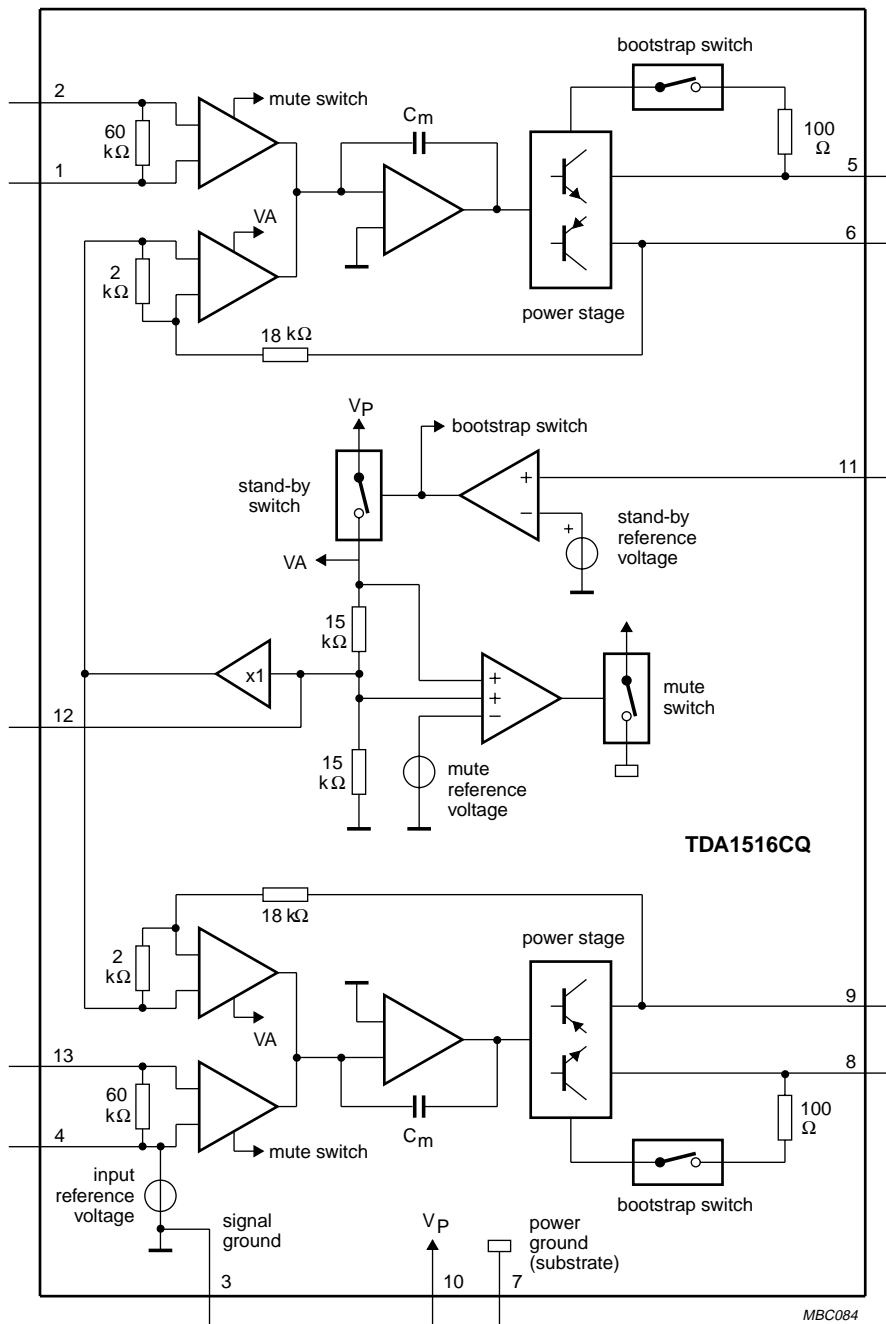

Fig.1 Block diagram.

24 W BTL car radio power amplifier

TDA1516CQ

PINNING

SYMBOL	PIN	DESCRIPTION
-INV1	1	non-inverting input 1
INV	2	inverting input
GND1	3	ground (signal)
V _{ref}	4	reference voltage
OUT1	5	output 1
BS1	6	bootstrap 1
GND2	7	ground (substrate)
BS2	8	bootstrap 2
OUT2	9	output 2
V _P	10	supply voltage
M/SB	11	mute/stand-by switch
RR	12	supply voltage ripple rejection
-INV2	13	non-inverting input 2

FUNCTIONAL DESCRIPTION

The TDA1516CQ contains two identical amplifiers with differential input stages. It can be used for bridge applications. The gain of each amplifier is fixed at 20 dB. A special feature of this device is the mute/stand-by switch, which has the following features:

- low stand-by current (< 100 μ A)
- low mute/stand-by switching current (low cost supply switch)
- mute condition.

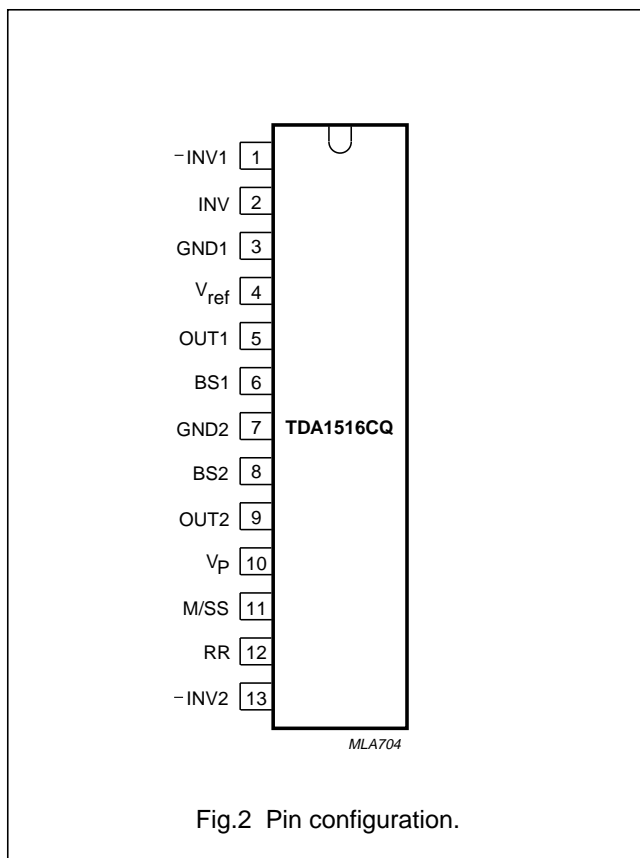

24 W BTL car radio power amplifier

TDA1516CQ

LIMITING VALUES

In accordance with the Absolute maximum System (IEC 134).

SYMBOL	PARAMETER	CONDITIONS	MIN.	MAX.	UNIT
V _P	supply voltage	operating	–	18	V
		non-operating	–	30	V
		load dump protected; during 50 ms; rise time ≥ 2.5 ms	–	45	V
V _{PSC}	AC and DC short-circuit safe voltage		–	18	V
V _{PR}	reverse polarity		–	6	V
	energy handling capability at outputs	V _P = 0	–	200	mJ
I _{OSM}	non-repetitive peak output current		–	6	A
I _{ORM}	repetitive peak output current		–	4	A
P _{tot}	total power dissipation	T _{case} < 75 °C; (see Fig.3)	–	25	W
T _{stg}	storage temperature range		–55	+150	°C
T _{vj}	virtual junction temperature		–	+150	°C

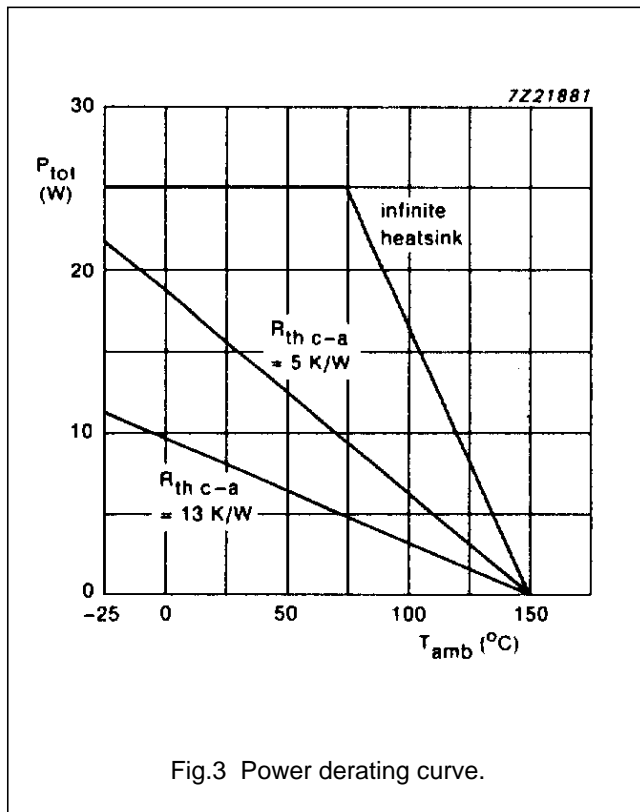

24 W BTL car radio power amplifier

TDA1516CQ

DC CHARACTERISTICS

$V_P = 14.4$ V; $T_{amb} = 25$ °C; unless otherwise specified. See note 1.

SYMBOL	PARAMETER	CONDITIONS	MIN.	TYP.	MAX.	UNIT
Supply						
V_P	positive supply voltage range	note 2	6.0	14.4	18	V
I_P	quiescent current		–	40	80	mA
V_O	DC output voltage	note 3	–	6.8	–	V
$ \Delta V_{OS} $	DC output offset voltage (pins 5 and 9)		–	–	100	mV
Mute/stand-by switch						
V_{SW}	switch-on voltage level		8.5	–	–	V
MUTE CONDITION						
V_{mute}	mute voltage		3.3	–	6.4	V
V_O	output signal in mute position	$V_I = 1$ V (max); $f = 20$ Hz to 10 kHz	–	–	2	mV
$ \Delta V_{OS} $	DC output offset voltage (pins 5 and 9)		–	–	100	mV
STAND-BY CONDITION						
V_{sb}	stand-by voltage		0	–	2	V
I_{sb}	DC standby current	$V_{11} \leq 0.5$ V	–	–	100	μ A
		$0.5 < V_{11} \leq 2$ V	–	–	500	μ A
I_{sw}	switch-on current	$V_{11} \leq V_{10}$; note 4	–	25	60	μ A
I_P	supply current	short-circuit to GND; note 5	–	5.5	–	mA

24 W BTL car radio power amplifier

TDA1516CQ

AC CHARACTERISTICS

$V_P = 14.4\text{ V}$; $R_L = 4\ \Omega$; $f = 1\text{ kHz}$; $T_{\text{amb}} = 25\text{ }^\circ\text{C}$; unless otherwise specified. See note 1.

SYMBOL	PARAMETER	CONDITIONS	MIN.	TYP.	MAX.	UNIT
P_O	output power	THD = 0.5%	15	17	–	W
		THD = 10%	20	22	–	W
		THD = 10%; note 6	21	24	–	W
		$V_P = 13.2\text{ V}$; THD = 0.5%	–	13.5	–	W
		$V_P = 13.2\text{ V}$; THD = 10%	–	17	–	W
		$V_P = 13.2\text{ V}$; THD = 10%; note 6	–	19	–	W
THD	total harmonic distortion	$P_O = 1\text{ W}$	–	0.05	–	%
B	power bandwidth	THD = 0.5%; $P_O = -1\text{ dB}$ with respect to 15 W	–	20 to 15 000	–	Hz
f_{low}	low frequency roll-off	-3 dB; note 7	–	25	–	Hz
f_{high}	high frequency roll-off	-1 dB	20	–	–	kHz
G_V	closed loop voltage gain		25	26	27	dB
SVRR	supply voltage ripple rejection	ON; notes 8 and 9	45	–	–	dB
		ON; notes 8 and 10	48	–	–	dB
		MUTE; notes 8 to 10	48	–	–	dB
		stand-by; notes 8 to 10	80	–	–	dB
$ Z_I $	input impedance		25	30	38	k Ω
V_{no}	noise output voltage	ON; $R_S = 0$; note 11	–	70	–	μV
		$R_S = 10\text{ k}\Omega$; note 12	–	100	200	μV
		MUTE; note 12	–	60	–	μV

Notes

- All characteristics are measured using the circuit shown in Fig.4
- The circuit is DC adjusted at $V_P = 6$ to 18 V and AC operating at $V_P = 8.5$ to 18 V
- At $18\text{ V} < V < 30\text{ V}$, the DC output voltage $\leq V_P/2$
- If $V_{11} > V_{10}$, then I_{11} must be $\leq 10\text{ mA}$
- Conditions: $V_{11} = 0$; short-circuit output to GND; switch V_{11} to mute or on condition (rise time $V_{11} > 10\ \mu\text{s}$)
- With bootstrap and a resistor of 100 k Ω from $V_P/2$ to the positive supply voltage (V_P). (Bootstrap capacitor of 47 μF)
- Frequency response externally fixed
- Ripple rejection measured at the output with a source-impedance of 0 Ω (max. ripple amplitude of 2 V)
- Frequency = 100 Hz
- Frequency = 1 to 10 kHz
- Noise voltage measured in a bandwidth of 20 Hz to 20 kHz
- Noise output voltage independent of R_S ($V_{\text{in}} = 0$)

24 W BTL car radio power amplifier

TDA1516CQ

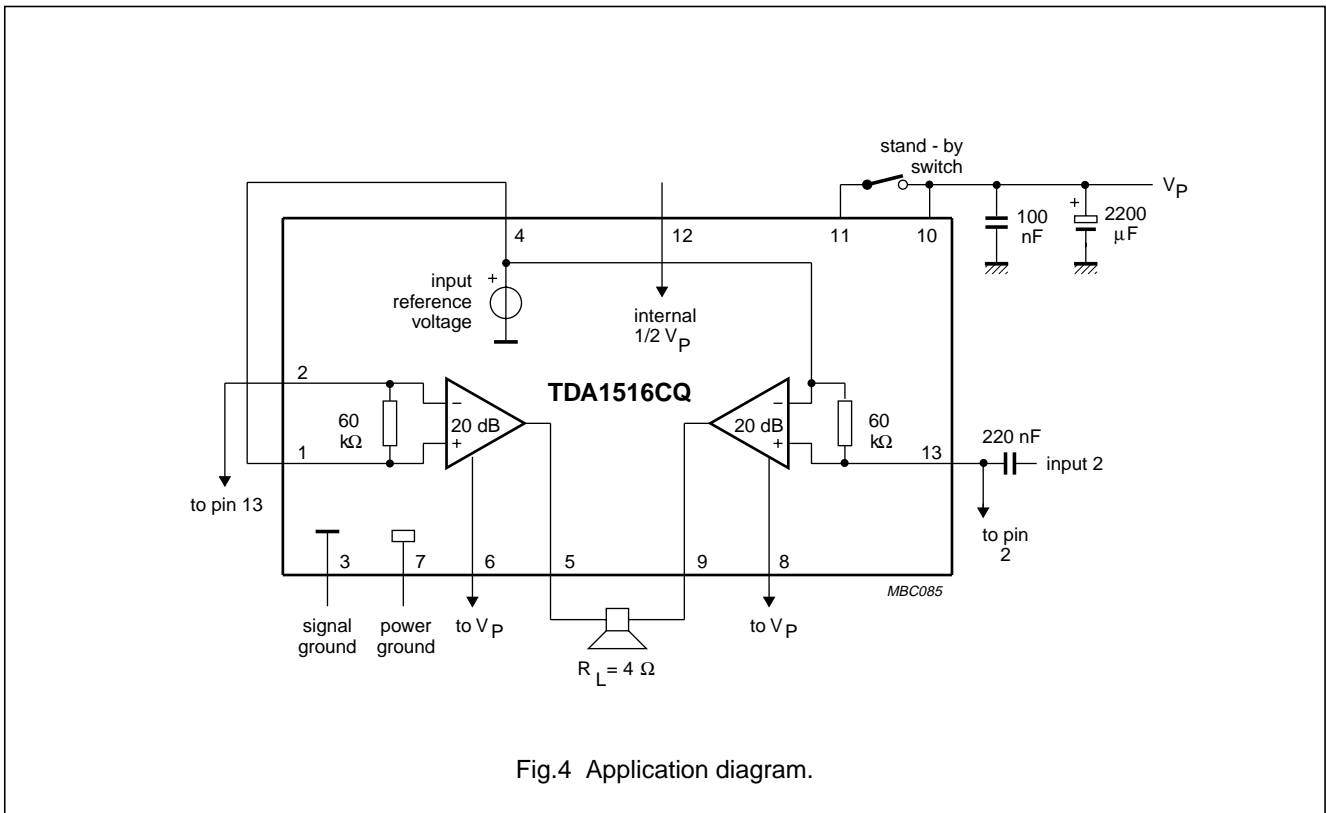

Fig.4 Application diagram.

24 W BTL car radio power amplifier

TDA1516CQ

PACKAGE OUTLINE

DBS13P: plastic DIL-bent-SIL power package; 13 leads (lead length 12 mm)

SOT141-6

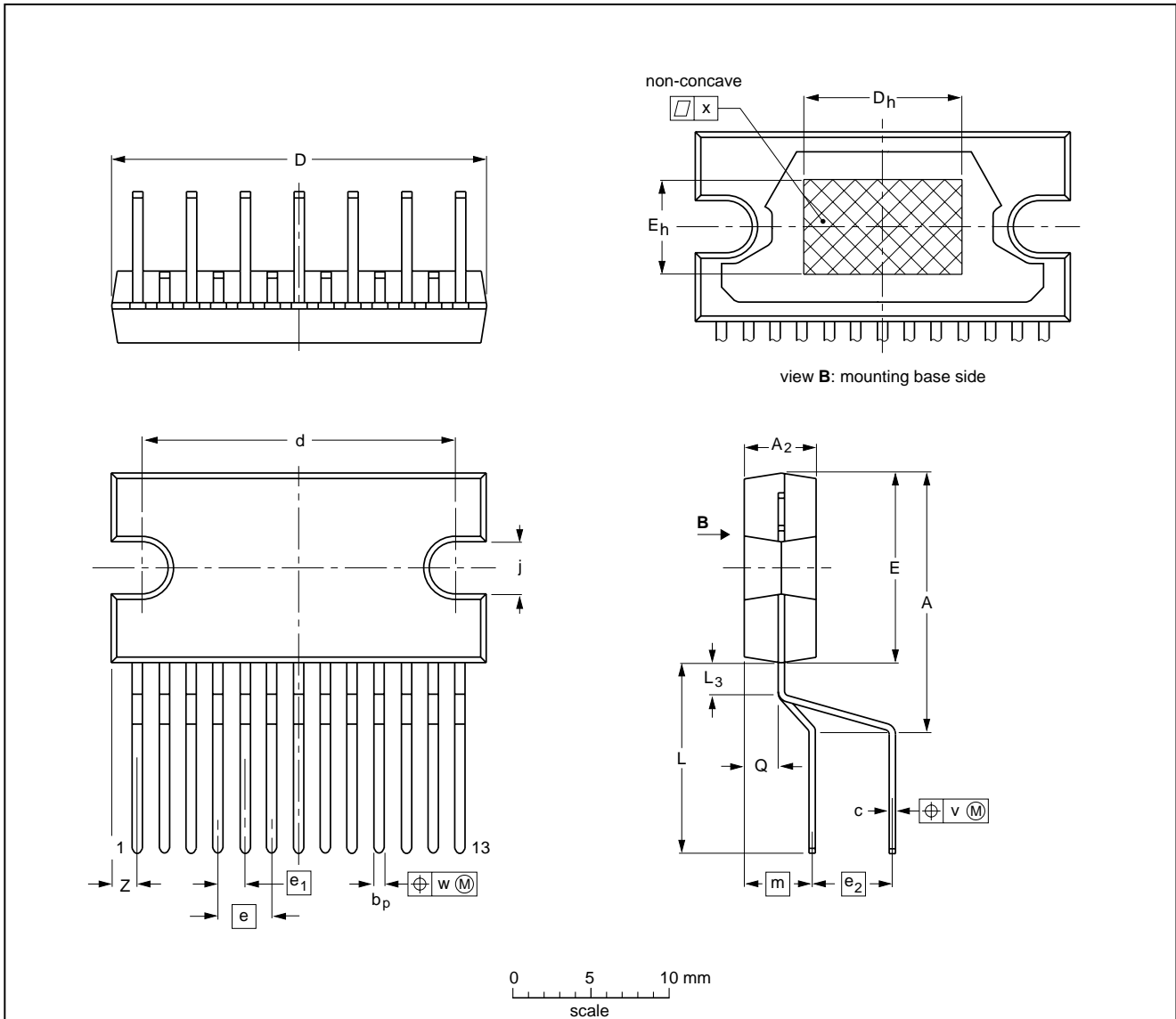

DIMENSIONS (mm are the original dimensions)

UNIT	A	A ₂	b _p	c	D ⁽¹⁾	d	D _h	E ⁽¹⁾	e	e ₁	e ₂	E _h	j	L	L ₃	m	Q	v	w	x	z ⁽¹⁾
mm	17.0 15.5	4.6 4.2	0.75 0.60	0.48 0.38	24.0 23.6	20.0 19.6	10	12.2 11.8	3.4	1.7	5.08	6	3.4 3.1	12.4 11.0	2.4 1.6	4.3	2.1 1.8	0.8	0.25	0.03	2.00 1.45

Note

1. Plastic or metal protrusions of 0.25 mm maximum per side are not included.

OUTLINE VERSION	REFERENCES				EUROPEAN PROJECTION	ISSUE DATE
	IEC	JEDEC	EIAJ			
SOT141-6						95-03-11 97-12-16

24 W BTL car radio power amplifier

TDA1516CQ

SOLDERING**Introduction**

There is no soldering method that is ideal for all IC packages. Wave soldering is often preferred when through-hole and surface mounted components are mixed on one printed-circuit board. However, wave soldering is not always suitable for surface mounted ICs, or for printed-circuits with high population densities. In these situations reflow soldering is often used.

This text gives a very brief insight to a complex technology. A more in-depth account of soldering ICs can be found in our "IC Package Databook" (order code 9398 652 90011).

Soldering by dipping or by wave

The maximum permissible temperature of the solder is 260 °C; solder at this temperature must not be in contact with the joint for more than 5 seconds. The total contact time of successive solder waves must not exceed 5 seconds.

The device may be mounted up to the seating plane, but the temperature of the plastic body must not exceed the specified maximum storage temperature ($T_{stg\ max}$). If the printed-circuit board has been pre-heated, forced cooling may be necessary immediately after soldering to keep the temperature within the permissible limit.

Repairing soldered joints

Apply a low voltage soldering iron (less than 24 V) to the lead(s) of the package, below the seating plane or not more than 2 mm above it. If the temperature of the soldering iron bit is less than 300 °C it may remain in contact for up to 10 seconds. If the bit temperature is between 300 and 400 °C, contact may be up to 5 seconds.

DEFINITIONS

Data sheet status	
Objective specification	This data sheet contains target or goal specifications for product development.
Preliminary specification	This data sheet contains preliminary data; supplementary data may be published later.
Product specification	This data sheet contains final product specifications.
Limiting values	
Limiting values given are in accordance with the Absolute Maximum Rating System (IEC 134). Stress above one or more of the limiting values may cause permanent damage to the device. These are stress ratings only and operation of the device at these or at any other conditions above those given in the Characteristics sections of the specification is not implied. Exposure to limiting values for extended periods may affect device reliability.	
Application information	
Where application information is given, it is advisory and does not form part of the specification.	

LIFE SUPPORT APPLICATIONS

These products are not designed for use in life support appliances, devices, or systems where malfunction of these products can reasonably be expected to result in personal injury. Philips customers using or selling these products for use in such applications do so at their own risk and agree to fully indemnify Philips for any damages resulting from such improper use or sale.